

The Mechanical Seal Industries Contribution to Energy Efficiency in Pumping Systems

Richard Smith

AESSEAL plc

Chris Booth BA, MBA

AESSEAL plc

SYNOPSIS

Sealing devices account for only a small fraction of the energy consumed by pumps; the scope for energy conservation at first appears limited. However, the paper details areas where significant energy conservation has been achieved by elegant sealing practices. Process industries have enjoyed savings in energy associated with seal cooling water circulation. A correlation between effluent reduction and carbon emission is postulated. Technology can provide the process industries with significant efficiency improvement in seal cooling. Case studies are reviewed from several industry sectors. API standards endorse many of these techniques as best practice. The mechanical seal industry contribution is key in assisting pump users to play their part in reducing adverse climate change.

1 INTRODUCTION

Pumping of liquids in the service and process industries is a significant user of energy, and consequently a major contributor to CO₂ emissions. The link between rising atmospheric CO₂ (fig 1) and climate change has been fiercely debated, but now appears to be generally accepted by mainstream science. (Reference 1) Industry leaders such as Branson (Virgin) and Browne (BP) have committed their corporations to developing technologies that will help reduce carbon emissions. Such actions may be visionary, or recognition of a significant market opportunity, or both. The reader is left to decide.

Can the pumping community (users, manufacturers & component suppliers) make a difference to carbon emission levels? In the UK, electric motors account for 40% of total electricity consumption. Pumping equipment is estimated at 32% of this, or 13% of total electricity demand. If the UK is typical of modern developed economies, then improvements in pumping efficiency can have a significant impact on carbon emissions. Can the pumping community rise to this global challenge?

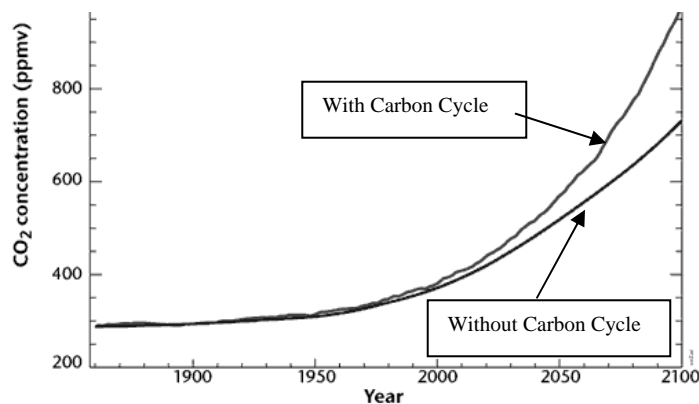

Fig 1

2 ENERGY SAVING AND MECHANICAL SEALS

Most pumps require a sealing device to prevent liquid escaping from where the drive shaft enters the pump casing (fig 2). In the developed world, mechanical seals have replaced traditional gland packing on the majority of newly installed industrial pumps. With many mature pump assets still in use the potential remains for reductions in energy consumption by replacement of gland packing.

Where mechanical seals are fitted, seal frictional losses account for as little as 1% of total pump power consumption, hence the potential energy savings from improved seal technology are low. However experience shows that much larger energy efficiency improvements can often be made by improvements to the seal support system.

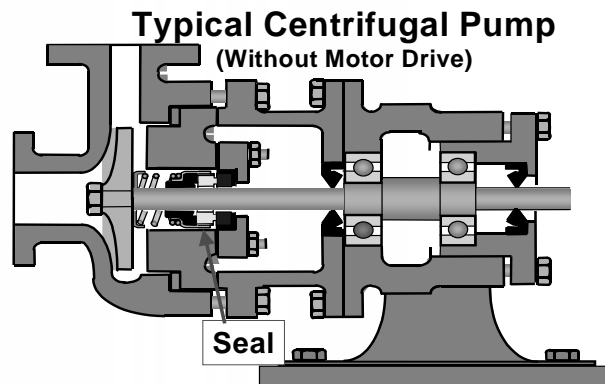

Fig 2

3 ENERGY SAVINGS FROM SEAL SUPPORT SYSTEMS.

Mechanical seals in process industries are often reliant upon supporting auxiliary fluid systems. Referred to as 'piping plans' or 'seal support systems', these improve the operating environment of the seal to provide reliable operation and longer seal life. The energy consumed indirectly by

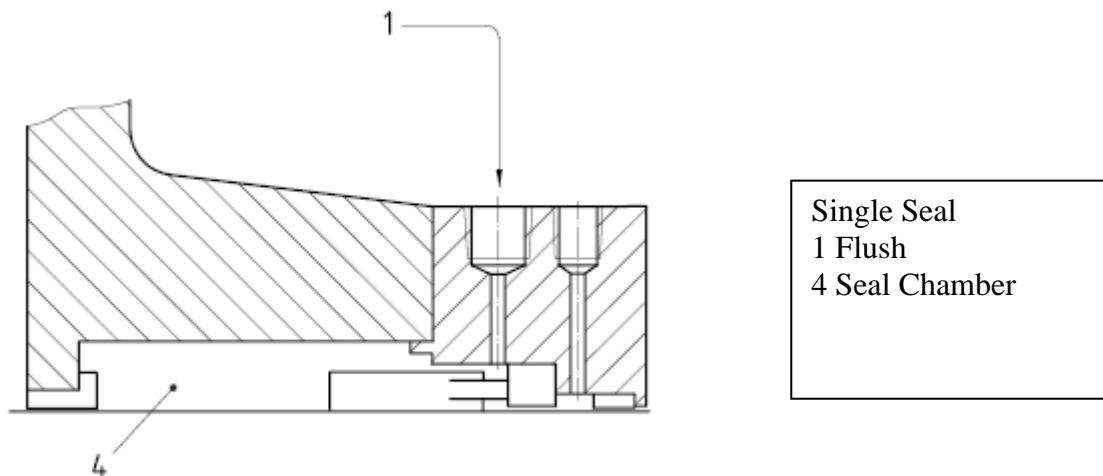

Fig 3a Typical single seal Piping Plan

the seal support system is often overlooked, but can be considerable.

The American Petroleum Institute (API) in its international seal standard API 682 (ISO 21049), (reference 2) recognizes 26 piping plans; many other variations are also used. These generally fall into two main groups:

a) 'Flush'

Clean, cool liquid is injected into the seal chamber to improve the operating environment.

b) 'Barrier or Buffer' (Fig 3a)

A secondary fluid is fed to the space between two co-axial mechanical seals to prevent atmospheric contact with the pumped fluid, improve seal cooling, or enhance safety. (Fig 3b)

With hot processes, a flush system injects cool liquid into the process stream, which must in turn be heated to compensate. Barrier systems remove heat from the process, then cool the secondary fluid before returning it to the seal. If the flush or barrier were not present, the process would require less energy. Heat exchangers are often used to cool the flush or barrier fluid, requiring a supply of pumped cooling water or a fan to drive air past the vanes of the exchanger.

A 'smart' approach to seal support systems can improve energy efficiency and provide significant reduction in energy costs and carbon footprint.

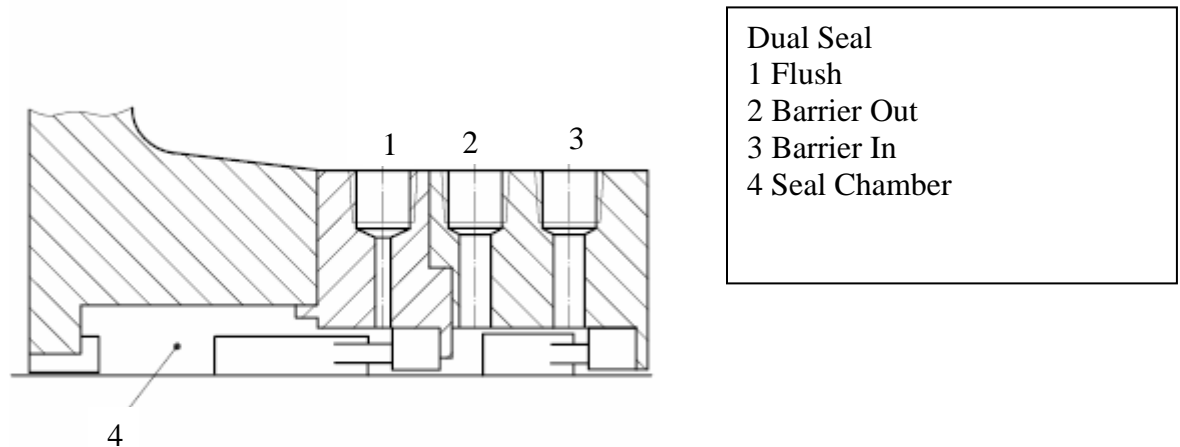

Fig 3b Typical dual seal Piping Plan

4 CASE STUDY - BOILER CIRCULATION PUMPS - CONVERSION FROM API PLAN 21 TO PLAN 23

This first example illustrates the efficiency difference between two (process side) flush piping plans. Single seals operating in higher temperature media often require additional cooling. This may be needed to improve the margin to vapour formation, to meet secondary sealing element (e.g. O rings) temperature limits, or to reduce coking or polymerisation.

There are two piping plans commonly used in industry, referred to here as API plan 21 and API plan 23.

4.1 API Plan 21

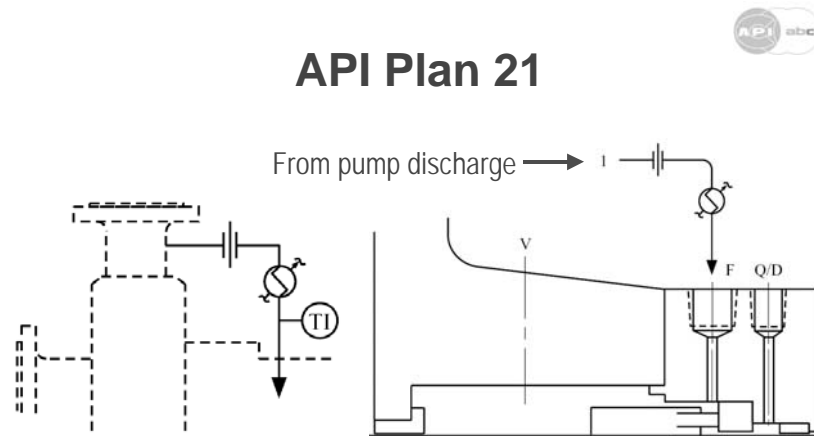

Recirculation from pump discharge through a flow control orifice and cooler, then into to the seal chamber.

Fig 4

In API Plan 21 (fig 5), process fluid is circulated from the discharge of the pump, through a restriction orifice and a cooler, then into the seal chamber. The cooler is removing heat from the process stream, reducing overall process energy efficiency.

4.2 API Plan 23

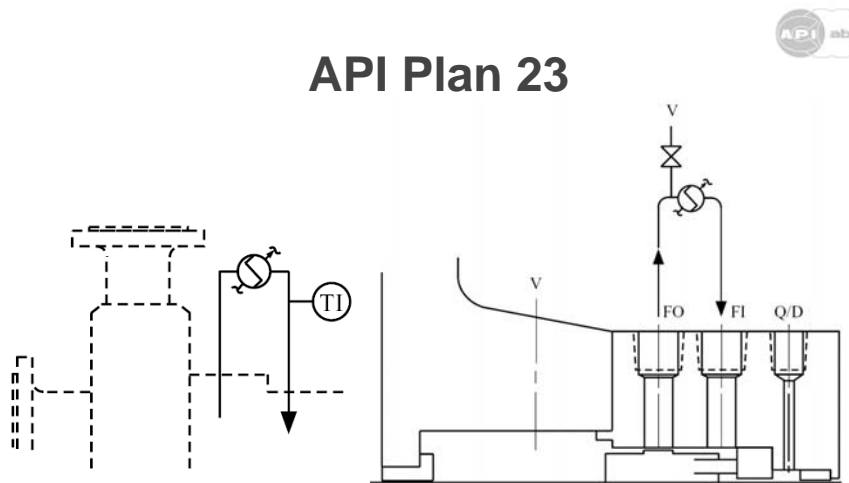

Recirculation from a pumping ring in the seal chamber through a cooler and back into the seal chamber.

Fig 5

In API Plan 23 (Fig 6), is a more efficient way to provide cooling for the mechanical seal. Liquid is re-circulated from the seal chamber, through a cooler, then back to the seal chamber. Circulation is driven by a rotating pumping ring in the seal chamber, which may be integrated with the mechanical seal. Instead of constantly cooling a part of the process stream, only the contents of the

seal chamber are cooled. This minimises the load on the cooler, since the heat to be removed is only the heat generated by the seal faces plus the heat soak through the seal chamber casing.

4.3 Plan 23 Boiler Feed Pump Application - Energy Saving

One such application was the boiler water feed pumps on a modern CHP plant supply at a paper recycling mill. Operating at 160°C, and seal chamber pressure 8 bar(g), this application serves to illustrate the difference between the two plans. The pumps were fitted with a traditional seal of 85mm diameter cooled by API Plan 21 configuration. Service life of the seals was less than 12 months, with associated problems of cooler fouling. A software package developed between the cooler manufacturer and AESSEAL was used to calculate cooler heat loads for both Plan 21 and Plan 23 operation. Plan 21 results demonstrated that the seal would be operating at seal chamber temperatures of 108°C, and with cooler heat load in excess of 14 kW. Using the same basic operating parameters, an SMSS 23 (Fig 6 & 7) mechanical seal on plan 23 operation gave significant efficiency improvement. Seal chamber temperature drops to 47°C, with the cooler heat load falling to 1.9 kW almost 1/8th of the heat load of the Plan 21 system. The reduction in cooler load does not reduce the power absorbed by the pump but provides for two potential savings. First, almost 12kW less heat is required to operate the boiler. Second, reduced load on the cooling water waste-heat removal system results in lower maintenance costs.



Fig 6 SMSS 23
A Modern Cartridge Design
Plan 23 Mechanical Seal

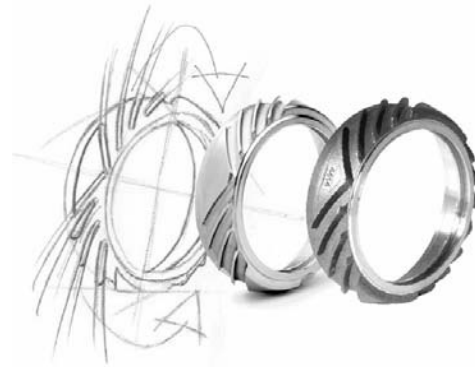

Fig 7 Bi Directional Seal
Circulating Device

4.3.1 Plan 23 Boiler feed Pump Application – Reliability Improvement

A similar exercise was undertaken on a ship application, which demonstrated similar reduction in cooler load. MTBF of the original plan 21 arrangement was <12months with cooler fouling being the root cause of failure. The SMSS plan 23 conversion has now been operating since 2002 with no failures to date.

4.3.2 API 682 3rd Edition ISO 21049 ‘best practice’

API 682 offers an excellent tutorial on the reliability improvements that can be obtained with plan 23 and states that plan 23:

.....is the plan of choice for all hot water services, particularly boiler feed water,is also desirable in many hydrocarbon services where it is necessary to cool the fluid to establish the required margin between fluid vapour pressure and seal chamber pressure.

.....This duty is usually much less than that in a Plan 21. Lessening the duty is very desirable because it extends the life of the cooler.

.....The industry has considerable negative experience with Plan 21 because of cooler plugging.

4.3.3 Industry Adoption

Industry adoption of the preferred and more efficient Plan 23 is currently low plan 21 is far more popular. This is because traditionally plan 23 seals were expensive due to the cost of including the pumping ring & complex tangential porting in the seal chamber. Modern machine tool techniques combined with innovative modular cartridge designs (fig 6) have made the implementation of such seals easier on both new and retrofit pumps. Cost has been reduced by fully integrating the pumping ring and ports into the seal cartridge. Development of efficient bi directional pumping rings (fig 7) serve further to simplify installation on between bearing multi stage machines

In a recent proposed design of a petrochemical facility to be built in the Middle East 10 % of the applications were originally specified as plan 21. After demonstrating the energy savings to be made, these were changed to plan 23. It is still common to find a high incidence of plan 21 on major projects where capital cost has been the over-riding factor, such as combined heat and power (CHP) plants.

5 CASE STUDY - EVAPORATOR PUMPS - CONVERSION FROM PLAN 32 TO PLAN 53

In this example energy efficiency was improved by converting from a single mechanical seal with external flush (plan 32) to a double seal with barrier system (plan 53a). The application was at a Scotch Whisky Distillery where pot ale, a by-product, is processed in a syrup evaporator to make animal feed.

5.1 API Plan 32 Efficiency Loss

There are three evaporator circulation pumps, which were fitted with single mechanical seals and a simple Plan 32 flush (Fig 8). Clean fluid from an external source is used to flush the seal chamber, to exclude solids or contaminants, and to reduce the temperature at the seal. It is also used to reduce flashing or air intrusion (in vacuum services) across the seal faces. The main driver for the use of this system is its low initial cost.

A survey of the evaporator system revealed the inefficiency of this flush plan. Syrup was being fed to the evaporator at the rate of 150 litres/min (L/m), but also being diluted by 2 L/m, per pump, of clean flush fluid. The additional 6 L/m of liquid into the process meant having to evaporate at least 4% more liquid. An analogy is having to walk 26 miles to actually only cover 25. In addition the injected flush water came from a mountain stream source at 5°C, so more heat was being added to the process to maintain evaporation temperature.

Heating the cold flush water to the evaporation temperature requires 19 kW, or 460 kW-hr per day. Evaporating the flush water requires over 200kW or 4800 kW-hr per day.

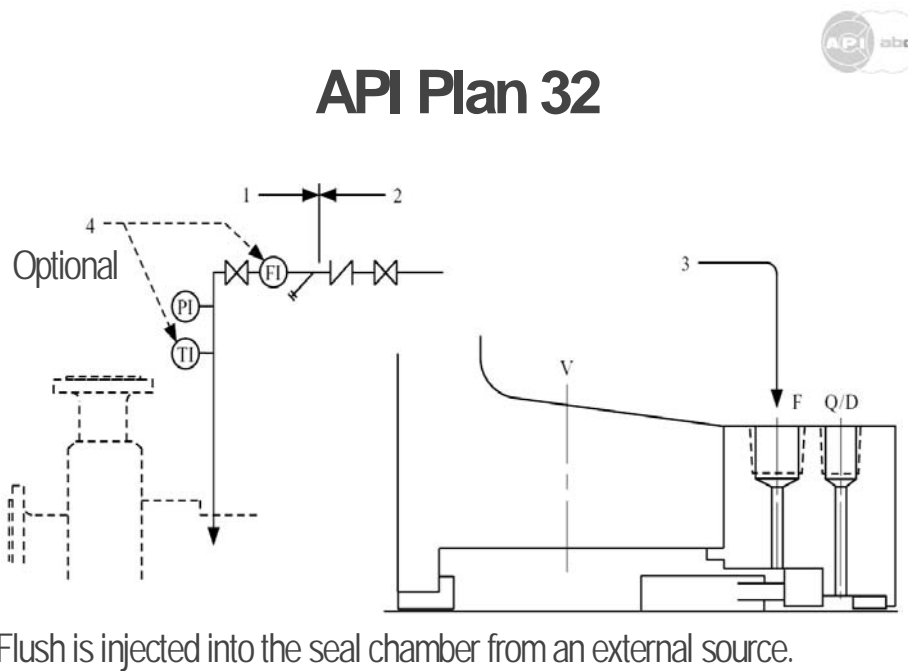
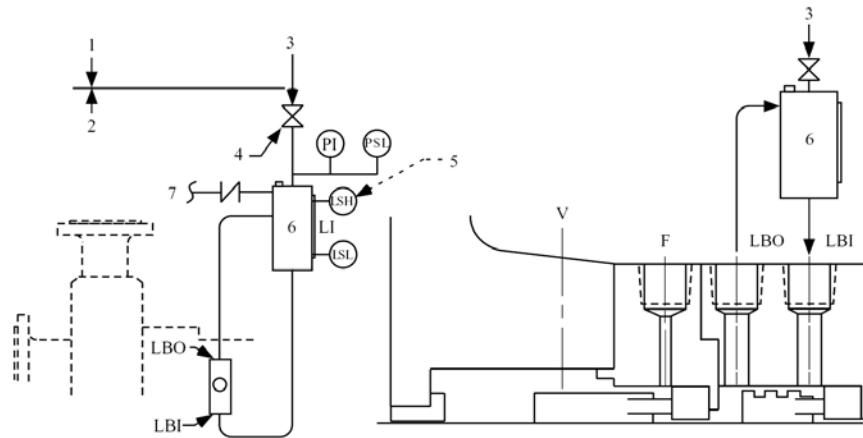

Fig 8

API Plan 53A



Pressurised external barrier fluid reservoir supplying clean fluid to the seal chamber. Circulation is by an internal pumping ring. Reservoir pressure is greater than the process pressure being sealed.

Fig 9

5.2 API Plan 53a Conversion Efficiency improvement

Conversion to a double seal system with plan 53A (Fig 9) eliminated the need for seal flush. A



Fig 10 Plan 53 W2 Seal Systems in use at a distillery in Scotland



Fig 11

small pressurised tank is introduced, containing 10 litres (Fig 11) of barrier fluid. This is circulated either by convection or by a small circulating device built into the seal. The pressurised barrier

fluid provides a clean liquid environment for the inner seal faces and prevents air intrusion to the vacuum. With all three pumps converted (Fig 10), syrup production increased from 88 to 98 tonnes/hr resulting in a significant reduction in plant running hours. In addition, over 5000 kW-hr per day was liberated for better use elsewhere.

5.2 Evaporator Plant Installations

Any business operating pumps on evaporator systems needs to consider with great care the piping plan used on the pump seals. Plan 32 is often found in many industries, including pulp & paper, sugar production & chemical process such as nylon manufacturing.

6 CASE HISTORY - WATER QUENCH - CONVERSION FROM QUENCH TO PLAN 53

A quench is similar to API Plan 62. Water from an external source is passed between two co-axial seals and away to drain. The water quench is used to prevent solids accumulating on the atmospheric side of the mechanical seal, and can considerably improve seal reliability.

6.1 Quench Usage and Effluent

This system (Fig 12) is common in many industries including Brewing, Distilling, Pulp & Paper, Corn Milling, Sugar Production, Dairy Processing, and Chemical Production.

Quench flow rates are typically 3 litres per min, per seal installation. In addition to the cost of the

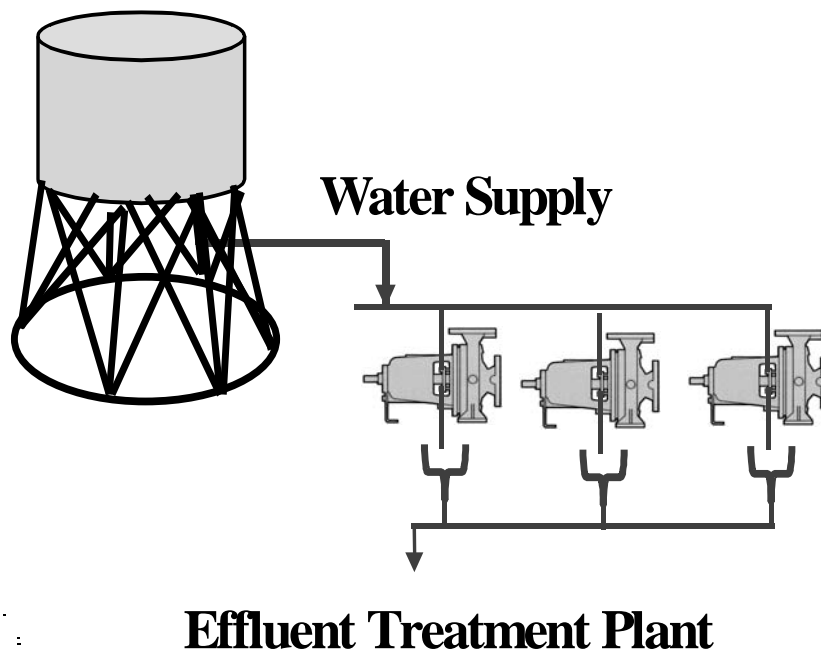

Fig 12

water used, the cost and energy consumption of effluent treatment should not be overlooked. The main driver for the use of this system is again its low initial cost

6.2 Thermosyphon Alternate plan 53a Effluent elimination

An alternative to this system is to use a barrier system (Fig 13), similar to API plan 53a. Such systems are self contained, and more importantly they **produce no effluent**. If the water supply is connected so as to both pressurise and maintain the level in the tank, no manual intervention is required, and maintenance costs are reduced. An air space can serve as an expansion volume, minimizing the effect of temperature changes. In the event of water supply interruption, the air volume and a check valve maintain pressure until supply is resumed.

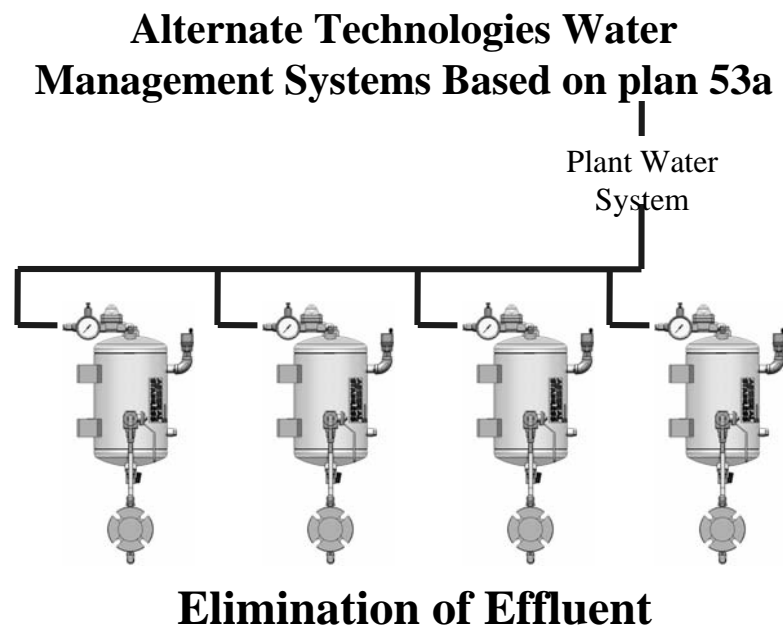

Fig 13

6.3 The Cost Of Effluent Treatment Energy Consumption & CO₂ Impact

Figures provided by a large UK Sewage treatment works (550,000 M³/day) indicate energy consumption of 0.15 kW.hr/M³. Treatment of industrial effluent is often more complex and uses smaller plants; the energy content for treatment will therefore be higher. Research in the Canadian paper industry (reference 3) indicates that modern pulp mill waste water treatment requires **0.86** kW.hr/M³. For aqueous process industries it is assumed that effluent treatment energy requirements will likely be within this range.

Carbon Emission Factors (reference 4) are available for UK energy use, using the UK's generating mix of fossil fuels, nuclear & renewable. Here a 1kW.hr saving is equivalent to a 0.501 kg CO₂ emission reduction. The Carbon Emission Factor differs between countries, e.g. South Africa publishes a figure of 1.0 Kg CO₂/kW.h

6.4 Energy Savings

Converting a pump seal from quenched to a barrier system provides annualized savings of 1577 M³ p.a.. This provides a power saving between 236 and 1352 kW.hr.p.a. In the UK, this equates to a CO₂ emission reduction between 118 and 678 kg.

Where an industrial plant generates its own power from production waste, power saved in effluent treatment can be put to better use, and to offset carbon production from other generators.

The technology is well proven with over 15,000 conversions to this systems over the past decade. Case histories are available from many different industry sectors. It is probable that the mechanical seal industry has saved many thousands of tonnes of CO₂ emissions as a result of these conversions.

6.5 UK Government support for industrial water savings

Enhanced capital allowances to support business investment in designated water efficient technologies were introduced in 2003. In 2007 the Chancellor announced that the Government will add a further three technology classes which will include **water management equipment for mechanical seals**.

7 CASE STUDY – CONVERSION FROM GLAND PACKING TO MECHANICAL SEALS BOILER FEED PUMP

7.1 Packing Glands

This case history involves the conversion of a boiler feed pump from a traditional soft packing gland (fig 14) to a plan 23 mechanical seal.

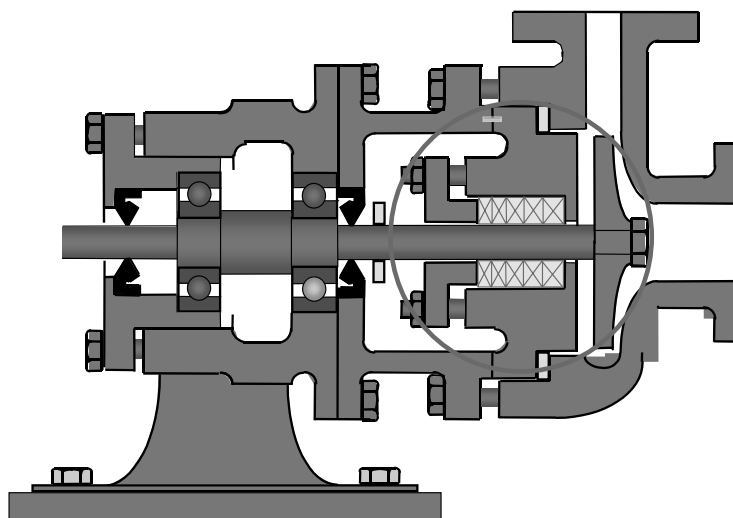
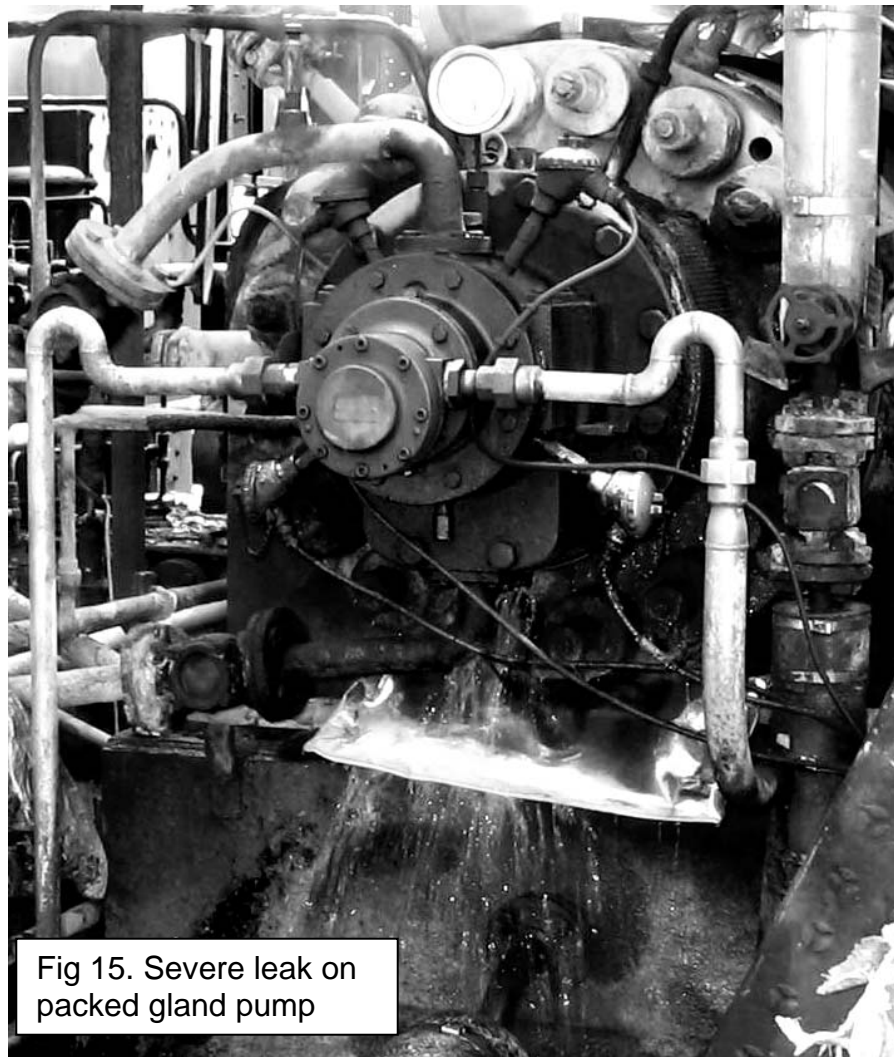

Fig 14

To help prevent the rubbing friction damaging the packing, the gland follower would be adjusted to allow a small leakage to flow, typically a slow drip rate. The leakage serves to assist in cooling and lubrication of the gland. As the packing and shaft wear, adjustment will be required to control the leakage rate.

7.2 Case Study Boiler Feed Pump Conversion

The case study in question is for a boiler feed pump at a Petrochemical facility in the NE of the UK. The pumps were installed in the late 70's and furnished with packed glands. The pumps are multi stage units with glands at both drive and non-drive end. This arrangement is typical of many applications around the world at chemical works and refineries. Most of the feed water pumps installed in this era were fitted with packed glands and many continue to run today using this technology. Leakage from the packed glands will be a pure loss to the operation. In this example the feed water in the pump was at 121°C. Losses through the packed gland would need to be made up with water from the treatment plant. The calculation of the energy loss is based the energy required to take the make up water from 10°C to feed water temperature of 121°C. In this instance the boiler plant is gas fired and the heat energy requirement can be translated into a nett CO₂ contribution. Due to a reduction in plant manning, the gland follower adjustment was only made when the leakage was severe. As a result, the average leakage rate from the pumps was about 1 litre/minute per gland (Fig 15).



7.3 Energy Savings.

With 8 pumps (16 glands) leaking on average 1 litre per min per gland energy loss is calculated at 124kW. The plant operates 24 hours per day 365 per year giving an annual energy loss of 1,086,240 kW.hr p.a.

The energy savings are purely based on heating requirements and do not include energy costs for water treatment, de aeration and any pumping. It is worth noting that the reduction in energy does not reduce the power absorbed by the pump but provides for savings in the combustion process and boiler operation costs.

7.4 CO₂ Savings

Investigation of the combustion process by site personnel indicated that 0.0282kg CO₂ is emitted per litre of water heated. With losses of 1 litre per min per gland (16 glands), there is a calculated saving of 237 tonnes of CO₂ per year. By comparison the average European high efficiency diesel car covering 20,000km per year would emit 3.2 tonnes per year, therefore the saving is equivalent to nearly 80 cars.

8 CASE HISTORY - MINERAL EXTRACTION SLURRY PUMPS – CONVERSION FROM GLAND PACKING TO MECHANICAL SEAL

Population growth, economic development and climate change have led to pressure on the water supply in many parts of the world including the UK. According to the OECD, (reference 5) access to reliable and safe water represents one of the greatest challenges facing humanity in the 21st century. The use of flush water in pumping applications, sometimes in large quantities, must be questioned. This practice is still widespread around the world.

The final case history is the conversion to mechanical seals of a number of large slurry pumps with packed glands. The Debswana operation consists of various diamond mines at Orapa in Botswana, a dry semi-desert area. Essential to the operation are slurry pumps pumping Kimberlite and Iron Silicate. These applications are amongst most abrasive in the slurry-pumping world.

8.1 Gland Water Requirement

The packed glands on the pumps needed flush water injection (Plan 32) into the process media, at a rate of 60 L/m to exclude slurry from the seal chamber. If the water supply failed, damage occurred to the gland within 30 seconds. Only 10% of the flush water is recoverable from the process. A typical train of five pumps consumes 134 Million Litres per annum. of water from underground sources. Due to constant extraction over many years, the water table was dropping and the resource was threatened. An official mandate was tabled to reduce water consumption by 10% immediately and 15% in the medium term. Pipelines from various alternative sources were considered. The most effective, and most extreme, was to build a 600km pipeline from the Okovango delta to Orapa at a cost of \$US 30M. This could have endangered water levels in the delta, a world heritage site.

Alternate Technologies Double Slurry Seal & Water Circulation System Plan 54

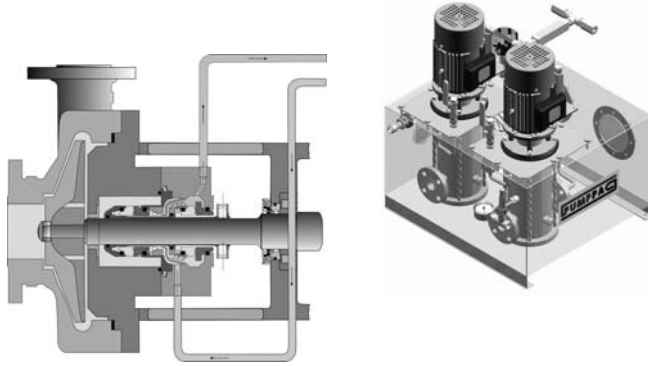

Fig 16

8.2 Double Seal Conversion

Fitting double seals with water circulation systems (Fig 16) to just 18 pumps reduced gland water consumption by a significant proportion of the 10% total savings required across the site. A further 50 seals and systems have now been installed, covering all the pumps using large volumes of gland service water.

8.3 Energy Saving

The primary motivation for the conversion was to tackle the issue of aquifer depletion, however

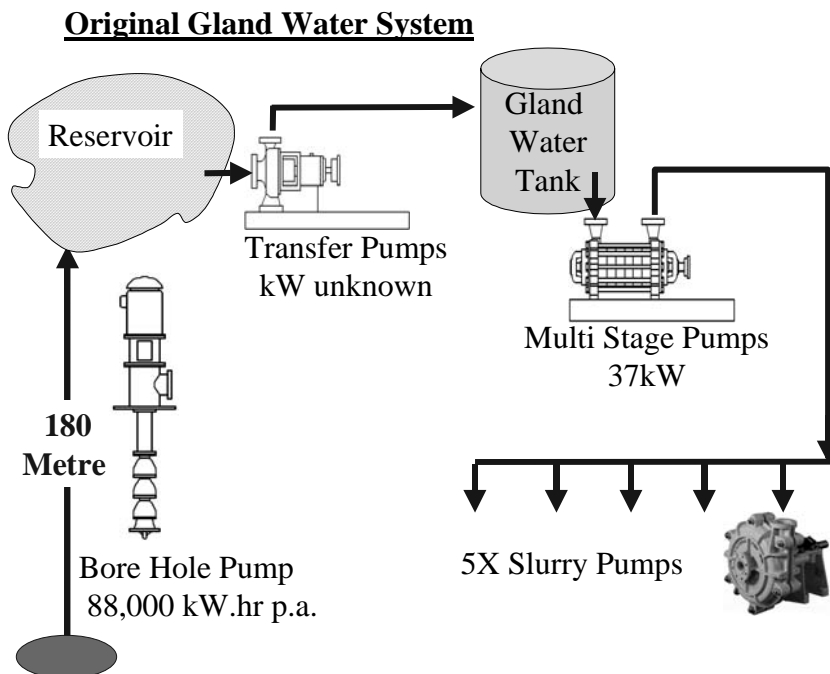

Fig 17

the secondary benefit of energy conservation should not be overlooked. The complete original gland water system needs to be considered. The system illustrated at Damtshaa mine (part of the Debswana Operation) is typical of many of the mines in Orapa (Fig 17). Energy saving are made because bore hole pumps are no longer required to lift the volume of gland water to a storage reservoir on the surface. Typically a bore hole is drilled to 250 metres with the water table at approximately 180metres. Bore hole pumps are of the helical rotor type and being belt driven are approximately 75% efficient. From the reservoir, a multistage pump increases pressure injecting the gland water into the pump casing. The calculated energy consumption of this system is 394,084 kW.hr p.a. African power generation is highly dependent on coal. For every kW saving a there is an equivalent atmospheric saving of 1Kg of CO₂.

The double seal conversion utilised a simple tank re-circulation system, with total energy consumption of less than 30,000kW.hr p.a. Hence energy savings of over 350,000 kW.hr p.a. were achieved.

9 CONCLUSIONS

Consideration of pump seal auxiliary piping systems needs to be given greater priority. The energy indirectly consumed is often ignored, with minimum capital cost being the prime driver when plants are designed. In Addition mature pump installations fitted with traditional high maintenance packing arrangements should be reviewed in terms of plant efficiency.

The mechanical seal industry has developed efficient, elegant solutions that provide the operator with higher reliability; lower life-cycle costs and reduced environmental impact.

Acknowledgements

The Authors would like to thank Mr. Andrew Walker Machines Engineer, Sabic UK Petrochemicals, Mr. Rob Adam Sales Director AESSEAL pty and Mr Peace Katse Debswana Orapa mines, for their assistance in the preparation of this paper

10 REFERENCES:

1 Predictions of accelerated climate change

Cox P.M., Betts R.A., Jones C.D., Spall S.A. & Totterdell I.J. 2000 Acceleration of global warming due to carbon-cycle feedbacks in a coupled climate model Nature, Vol 408, pp184-187

2 Pumps - Shaft Sealing Systems for Centrifugal and Rotary Pumps

International Standard API 682 (ISO 21049) American Petroleum Institute.
3rd Edition, September 2004

3 Energy Cost Reduction in the Pulp and Paper Industry – An Energy Benchmarking Perspective

D.W. Francis, M.T. Towers and T.C. Browne
Pulp and Paper Research Institute of Canada
The Office of Energy Efficiency of Natural Resources Canada 2002

4 BNXS01:Carbon Emission Factors For UK Energy Use - Under Consultation

Defra. Market Transformation Program. Version 2.2 10 July 2007

5 Water: How to Manage a Vital Resource

Angel Gurría, Secretary-General, OECD
OECD FORUM 14-15 May 2007, Paris
www.oecd.org